



KAPP-CHEMIE GmbH & Co. KG
Industriestr. 2 -4, D-56357 Miehlen

Product specification

Product name: **Kappasorb 16 g Beutel**

Version of: 16.08.18

Scheme 16 g gelling granules sachet

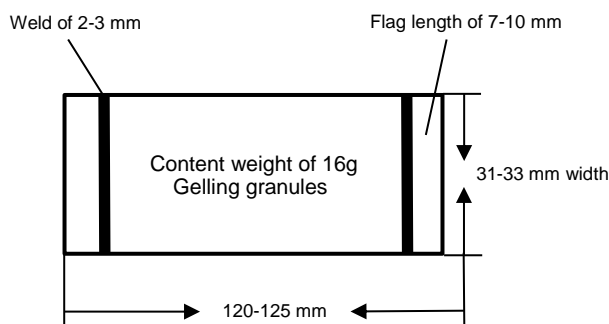

Product Parameters

Gelling granules:	Natrium polyacrylate, cross-linked
Swelling time PV 2700-148:	< 120 s
Soluble film:	PVA film 35 – 40 µm, limited cold resistant
Dissolving time:	< 20 s
Tear strength:	
Cross seam:	> 11 N
Longitudinal seam:	> 15 N

Measures

Sachet length:	120 – 125 mm (120 – 125 mm to film end)
Width cross seam:	31 – 33 mm toler
Length flags:	7 – 10 mm
Weld:	2 – 3 mm
Content weight:	16 g tolerance + 1 g

In process control:

Stress test: checking cross and longitudinal seams, turning, bending and kneading sachet, checking film for holes and any leakage of product

Packaging

Cardboard box white, contains 2 x 100 pcs. 16g soluble bags in inner PE closure bags (= 200 sachets).

Computer printout, valid without signature

We guarantee the contractual quality of our product within the scope of our "General Conditions of Sale and Delivery". The above specification parameters reflect the criteria of quality checks. They do not constitute a legal warranty of certain properties of the product or its suitability for a correct purpose. For products supplied by us in metal packaging, shelf life is limited to 180 days after delivery due to possible rust formation.